

業務部

REVISIONS		
ISS	ZONE	DESCRIPTION\PER REQUEST\DATE
B	A-1	NO.2 AND NO.7 WERE CHANGED\RD-DM90050901C\
	B-1	05-09-01'

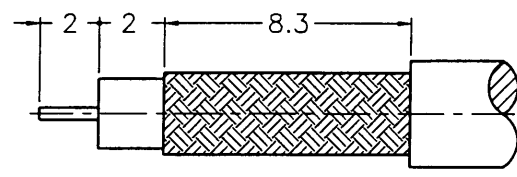

RECOMMENDED  
CABLE STRIPPING DIM'S  
(建議剝線尺寸)

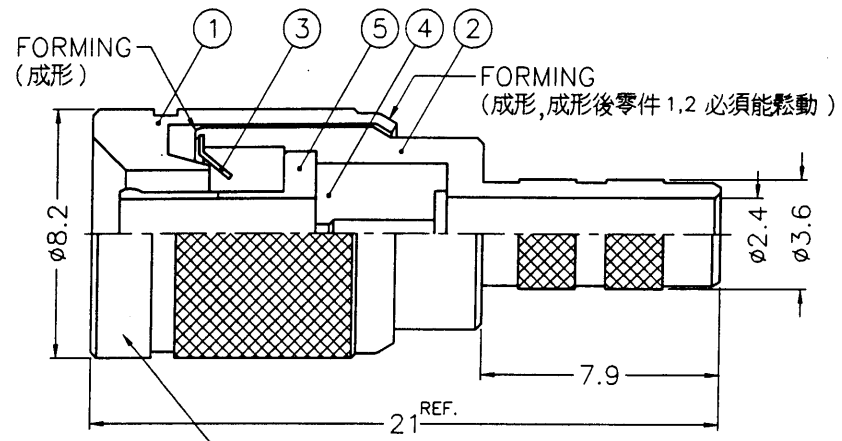
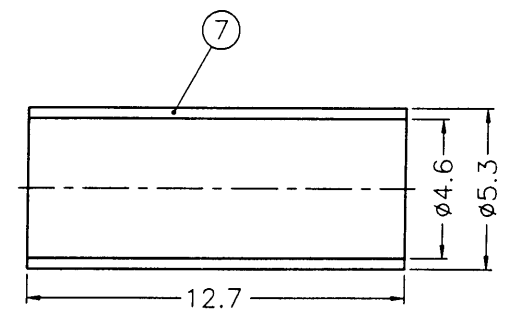
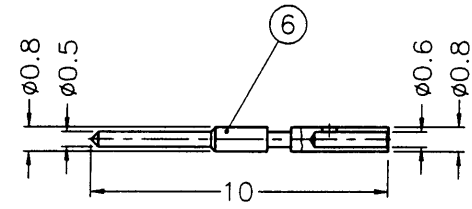

- NOTES: FINISH (PLATING THICKNESS IN MICRO-INCHES)
1. BRASS PER QQ-B-626
  2. BERYLLIUM COPPER PER QQ-C-530
  3. NICKEL PL. 100 MIN. THICK OVER COPPER STRIKE
  4. GOLD PL. 3 MIN. THICK OVER NICKEL PL. 100 MIN. THICK OVER COPPER STRIKE
  5. GOLD PL. 30 MIN. THICK OVER NICKEL PL. 100 MIN. THICK OVER COPPER STRIKE
  6. TEFLON MIL-P-19468

出圖  
2001. 5. 10  
設計部

1. CRIMPED FERRULE  
HEX CRIMP SIZE .178"
2. CONTACT PIN TO SOLDER

NO.	DESCRIPTION	MATERIAL	FINISH	Q'TY	DRAWING NO.
7	FERRULE	COPPER	NOTE 3	1	FR-53/46X127C
6	CONTACT PIN	NOTE 1	NOTE 5	1	1231121D2-6-08/06
5	OUT CONTACT	NOTE 2	NOTE 4	1	1231121D1-6-B
4	INSULATOR	NOTE 6	NATURAL	1	1231121D2-4T-75
3	SPRING	NOTE 2	NATURAL	1	123-PLUG-SPR
2	BODY	NOTE 1	NOTE 3	1	1231121D3-2-36/24
1	SHELL	NOTE 1	NOTE 3	1	1231121D2-1

DIMENSIONS ARE IN MILLIMETERS				PART NO.	
UNLESS OTHERWISE SPECIFIED TOLERANCES				APPROVED <i>Gacky</i> DATE 05-09-01'	
0.5-6	= ±0.2			CHECKED <i>Gacky</i> DATE 05-09-01'	
6-30	= ±0.4			DRAWN <i>Ala</i> DATE 05-09-01'	
30-120	= ±0.6				
120-315	= ±1				
315-1000	= ±1.6				
1000-2000	= ±2.4				

Amphenol - Kai Jack		TAINAN TAIWAN	
TITLE	1.0/2.3 CRIMP PLUG (FOR 8 COAX 2.5C-2V CABLE)		
DRAWING NO.	KJ-1231121D3-003-N/3GT30G-75		
FILE NO.	F:\DWG\123\121D3\003\75\N3GT30G		

RDBPR12141